

Modelo factorial confirmatorio de la formación del capital intelectual en la era COVID-19

Confirmatory factorial model of intellectual capital formation in the COVID-19 era

Francisco Espinoza Morales ^a, Cruz García Lirios ^b

Abstract:

The objective of this study is to explain the performance of a knowledge network, understood as a management, production, and transfer system between the demands of the environment and the capabilities of the organization. A non-experimental, cross-sectional and correlational study was carried out with a non-probabilistic sample selection of 100 administrators, teachers and students of a public university, considering their interaction in professional practices. The results show a confirmatory structure of three components related to the formation, production, and transfer of knowledge, although the relationship matrix suggests the inclusion of another factor alluding to the creation of knowledge observed in creative organizations. The contrast of the model in another sample and study context is recommended, as well as the adjustment of the dimensions to a model with the inclusion of a fourth factor.

Keywords:

Network, management, administration, knowledge, learning

Resumen:

El objetivo de este estudio es explicar el funcionamiento de una red de conocimiento, entendida como un sistema de gestión, producción y transferencia entre las demandas del entorno y las capacidades de la organización. Se realizó un estudio no experimental, transversal y correlacional con una selección de muestra no probabilística de 100 administradores, docentes y estudiantes de una universidad pública, considerando su interacción en las prácticas profesionales. Los resultados muestran una estructura confirmatoria de tres componentes relacionados con la formación, producción y transferencia de conocimiento, aunque la matriz de relaciones sugiere la inclusión de otro factor alusivo a la creación de conocimiento observado en las organizaciones creativas. Se recomienda el contraste del modelo en otra muestra y contexto de estudio, así como el ajuste de las dimensiones a un modelo con la inclusión de un cuarto factor.

Palabras Clave:

Red, gestión, administración, conocimiento, aprendizaje.

Introduction

Broadly speaking, a knowledge network is a climate of tasks centred on relationships of empathy, trust, commitment, entrepreneurship, innovation and satisfaction, but in a complex sense, it is based on vertical and bidirectional communication, with mutually influential leaders and followers, as well as a management and administration system focused on talents (Aguilar et al., 2016).

However, in the framework of neoliberal globalization, educational policies have focused on the quality of

processes and products according to a system of evaluation, accreditation, and certification. In each of these phases, those who make up an institution or organization dedicated to the management, production and transfer of knowledge are subject to institutional guidelines that determine the financing, subsidy, or forgiveness of payments for public services (Carreon et al., 2014). To the extent that Higher Education Institutions (HEIs) adjust their capabilities to state requirements, they circumscribe their strategies and functions to an autocratic relationship between leaders and talents by prioritizing unidirectional communication and extrinsic

^a Autor de Correspondencia, Universidad de Sonora, <https://orcid.org/0000-0002-4552-5893>, Email: fespinoz@uson.mx

^b Universidad Autónoma del Estado de México, <https://orcid.org/0000-0002-9364-6796> Email: cgarciali@uamex.mx

motivation, but if these HEIs compete for financial resources, then they develop cultures of success and climates of innovation oriented to the management, production, and transfer of knowledge (Carreon et al., 2015). Even the formation of knowledge networks is aimed at acquiring competitive advantages derived from a flexible culture, innovative climate, and trust for knowledge entrepreneurship, being the commitment and satisfaction of talents key factors in the development of the organization (Carreon et al., 2016).

However, organizations subject to evaluation, accreditation and certification focus their capabilities on the asymmetric relationship between their leaders and talents, with a vertical decision-making structure prevailing. In this authoritarian scenario, talents are assumed as resources or instruments, reducing their abilities to the execution of knowledge (Carreon et al., 2017). In contrast, when transformational leaderships emerge that delegate decisions to talents and promote the development of their capabilities, organizations focus on the production of knowledge rather than the reproduction and transfer of knowledge. This is a scenario in which the diversification of strategies and functions in talents and leaders would explain the degree of entrepreneurship and innovation, as well as the commitment and satisfaction of the actors involved (García, 2004). In such a scenario, organizational development has been explained from theories that highlight the importance of human relationships and motivations. From the humanistic approach of organizations, globalization is a guiding axis of emotions, feelings, and affections. In this sense, the logic of globalization understood as the maximization of production and consumption relations with respect to cost reduction, is disseminated as a basis for management, production, and knowledge transfer. Therefore, individuals are considered instruments of persuasion and dissuasion to arrive at the ends of profit. It is a rational choice process in which two principles prevail; 1) win-win that consists of an intensive negotiation in which those involved end up with a benefit greater than the costs invested and 2) zero sum where they are involved in the dilemma of winning or losing (Acar & Acar, 2014). In this way, the logic of rational choice has been challenged for excluding from benefits those who are involved in the dilemma of winning or losing.

In contrast, the social capital approach assumes that 1) people who share resources and assets are an end in themselves; 2) the instruments to share goods and resources suppose affections such as trust and cooperation; 3) therefore, the main asset of an organization is in the relationship itself rather than in resources, goods, or people (Hernández & Valencia, 2016). The theory of social capital considers that relationships between people are networks of production

and reproduction of information and knowledge. It is a system of reciprocities in which a sender is a receiver in the process of information dissemination, decision making and execution of intentions (Omotayo & Adenike, 2013). The information and knowledge network includes dissuasion and persuasion processes based on the degree of internal and external expectations of the network. If a climate of trust prevails in the network, then it will be possible to observe cooperation in undertaking and innovating tasks (Anicijevic, 2013).

Precisely, continuous relationships –organizations with permanent control, surveillance, and motivation– and discrete relationships –organizations with sporadic and unidirectional climates– determine the complexity of social capital, since the levels and degrees of interrelation affect the structures and phases of organizations –self-regulation, dissipation, adaptation and dynamism–. Complex organizational systems can be reflective or formative. The non-linear emergence of an organization can be reflected in its degree of entrepreneurship, innovation, or resilience (García, 2005). Instead, the determinants of a complex organizational system can form a structure of nonlinear relationships. In this sense, the determinants of entrepreneurship, innovation or resilience can be factors alluding to the pandemic such as stigma, self-care, or self-organization (Quintero et al., 2016). Although complex organizations seek to differentiate themselves and integrate with other organizations, the continuity of their processes and the emergence of their resources confines them to complexity (Cruz et al., 2016). The theory of social capital exalts continuous relationships but considers discrete relationships as the foundation of continuous ones, since organizations produce knowledge from latent processes such as psychological ones (Saansongu & Ngutor, 2012).

However, network analysis theory studies the structure of social capital, which it identifies as a graph. It is a conglomeration of implicit or tacit relationships that organizations establish as the objectives and goals are adjusted to the demands of the environment and the corresponding innovations (Mendoza et al., 2016). Consequently, the graph includes nodes and arcs or instances and relationships of knowledge production in the case of departments or task teams. Unlike social capital theory that focuses on relationships or arcs, network analysis theory considers that nodes are more relevant than arcs, since it is these instances that establish innovations and anticipate changes without the need to act into account the arches (Robles et al., 2016). In this way, the associated nodes can be identified as dyads or triads, but if they share an organizational culture such as quality or success, then they are unimodal,

configuring an order or number of total nodes included in the graph (García, 2006). Once the order or number of nodes has been established, the density estimate is established by dividing the existing relations by the possible relations. Such relationships can be unidirectional –twitter– or bidirectional –Facebook–. In both cases it is possible to calculate the directional weight (García, 2007).

In the case of organizations that require other organizations, their directional weight can be significant and close to one, but if rather other organizations are the ones that need to establish relationships with it and such matter does not imply a benefit for it, the directional weight is determined by connection demands more than by connection needs (Sales et al. 2016).

In the case of bidirectional or multidirectional nodes, the estimation is divided into the information inputs and outputs, the sum of both connections establishes its directional weight. If such estimation is higher with respect to other nodes, then it is considered that such organization is preponderant in the graph (García, 2015). Implicit processes can also be established by calculating the directional weight required for an organization to link with another distant or selective organization. In this way, organizations configure a graph of estimated relationships and another graph of latent relationships (Escobar, 2014).

In the case of estimated relations graphs, they provisionally define the conjunctural power of a node, but the latent relations graph determines the historical influence of the node. The difference is substantial because conjunctural power refers to the probability that an organization has to respond to external demands based on its intermediation, but historical influence determines the potential that an organization would have if its resources would establish a unimodal culture.

This is how organizational complexity alludes to power and influence represented in knowledge graphs, information networks, production nodes and relationship arcs. Social capital theory and network analysis theory explain the complexity of organizations as graphs, nodes, or arcs, while describing cultures and exploring meanings between actors (García et al., 2012).

If an organization is the result of the relationships between its talents, then its culture reflects the type of graph that it builds in response to the demands of the environment and internal resources. Organizational cultures allude to their uses and customs, values and norms inferred from the meanings of their symbols, their symbolic structure materialized in rituals, their autonomous or semi-autonomous sectors, their internal and external dialectics, their representations concerning surrounding information

and their social identity. Based on these characteristics, the analysis of complex organizations is limited to their culture, leadership, and climate.

Thus, autocratic organizational cultures depend on leadership and task climates more than their talents and motivations. In contrast, complex organizational cultures are encouraged by the production of knowledge of their talents and the motivation of their leaders (García et al., 2015). Autocratic cultures form graphs in which the continuity of discourses, conformities and isomorphism prevails, while complex organizations develop cultures and relationships and are sporadic in their processes that not only guide them in their adaptation or self-regulation, but also define them as emerging and dynamic (García et al., 2016). The leaderships of autocratic cultures are predominant nodes of decision but confined to values and norms of obedience and conformity. In complex organizational cultures, their nodes are latent leaderships that emerge when external demands exceed internal resources, or when relationships between nodes require innovative processes that generate opportunities and capabilities (Vázquez et al., 2016).

Regarding information and knowledge, autocratic cultures reproduce arcs while complex organizations generate latent and observable relationships, while structuring their objectives and goals based on the contingencies of the market or state institutionalism (Ortiz & García, 2008). In other words, autocratic organizations make up power structures and cultures of domination, while complex organizations structure cultures of innovation oriented towards influencing their talents and leadership (Pérez et al. 2017).

However, complex organizations differ from each other based on the relationships between their nodes and their contact intentions. Organizational avoidance is assumed as a factor of complexity, since it involves the establishment of latent relationships (Pérez et al., 2016). In autocratic organizations, contact avoidance refers to a negative task and relationship climate, but in complex organizations it implies a culture of entrepreneurship and latent innovation in parallel to the relationships established with the other nodes. Autocratic organizations assume that contact can be superficial or intimate as arcs intensify, but complex organizations consider contact avoidance as a preliminary assessment of the node towards leadership and talent. Therefore, the avoidance of contact implies a latent relationship that will materialize in influence and innovation rather than in a relationship of power, obedience, and conformity (García, 2004). Contact avoidance is subject to a series of internal processes in the organization such as categorization and identity. By the nodes establish membership categories to exclude other nodes and avoid correspondence,

organizations become more complex based on the differentiation of their talents and leadership (García, 2005).

In contrast, an organization that includes its talents and leadership in the same category not only generalizes its opportunities and capabilities, but also promotes superficial or autocratic relationships (García et al., 2016).

Therefore, organizational cultures are structured in networks from their internal differentiations and the choice of contact relationships. A greater number of connections or arcs supposes a greater complexity, but also a latent structure of relationships. Complex organizational cultures generate information from arcs, nodes, and graphs, but limited to the categorization and identity of their leadership and talents rather than external demands and internal resources, market opportunities or institutional guidelines. In such a process, complex organizations produce information to influence other similar organizations, although organizational cultures around power –obedience and conformity– coexist with complex organizations.

The objective of this work is to establish the validity of an instrument that measures the performance of a knowledge network, focused on the weighting of organizational complexity in order to explain the neural networks (learning between teachers, students and administrators) that are structured in the processing and assimilation of information concerning the self-regulation, dissipation, adaptation and dynamics of organizations in the face of contingencies, risks and uncertainty of the environment.

Formulation: In the framework of educational policies focused on the evaluation, accreditation, and certification of the quality of its processes and products, will a theoretical network of knowledge, focused on professional training and skills learning, fit in with another weighted network? from your incoming, hidden, and outgoing layers of knowledge?

Null hypothesis: Given that the knowledge network develops a culture of success directed at quality; evaluation, accreditation and certification of its processes and products, the weighting of its learning, indicated by self-regulation, dissipation, adaptability, and dynamism will be adjusted to its work culture.

Hypothesis alternate: Although the knowledge network is guided by a culture of success in response to quality educational policies, the management, production, and transfer of knowledge, measured in its incoming, hidden and outgoing layers, are different from its self-regulation, dissipation, adaptability and dynamism.

Method

A non-experimental, cross-sectional, and exploratory study was carried out. A non-probabilistic selection of 100 administrators, students, and teachers from a public university in Edomex was carried out. A selection of 100 students enrolled in professional practices and social service related to pandemic care was made. According to the literature on empirical model testing, the minimum number is 100.

67% are women and 33% men. 59% mentioned being between 18 and 22 years old ($M = 21.34$; $SD = 0.12$), 20% declared being between 22 and 29 years old ($M = 25.23$; $SD = 0.25$), the remaining 21% indicated an age greater than 29 years ($M = 33.12$; $SD = 0.32$). 33% stated that they had not completed university studies, 32% have completed bachelor's degrees, 20% master's studies and 15% doctorate studies. 32% declared family monthly income of less than 3,500 pesos ($M = 3,254$; $SD = 21.23$), 55% said that their family earned between 3,500 and 7,000 pesos per month ($M = 4,562$; $SD = 234.12$) and the remaining 13% indicated that their family earned more than 7,000 pesos in the last month ($M = 8,712$; $SD = 243.14$). 66% stated that they were single, 20% in a free union and 14% were married.

The Organizational Complexity Scale of García et al., (2016) was used, which includes four dimensions related to self-regulation, dissipation, adaptation, and dynamism. Each item is answered with one of five options ranging from 0 = strongly disagree to 5 = "strongly agree".

The Delphi technique was used for the homogenization of the words included in the reagents. The confidentiality of the answers to the written survey was guaranteed, informing them that the results of the investigation would not affect their academic or employment status. The surveys were conducted in the lobby of the university library. The information was processed in the Statistical Package for Social Sciences (SPSS) version 20.0. Mean, standard deviation, KMO, Bartlett's test, factor weights, and synapse weights were estimated.

Results

Figure 1 show fit and acceptance of the null hypothesis, that is, the possible theoretical relationships, show a structure like the weighted relationships. Scree allowed the estimation of the instrument was established with formation, production, and transfer. In other words, the contrast of the theoretical and empirical models suggests that in the long term, knowledge management is similar in terms of the findings consulted in the literature with respect to the observations of the present work. As the model includes the relationships between the indicators, it resembles the structure reported in the literature,

although the analysis of measurement errors will allow inferring the reliability of the model.

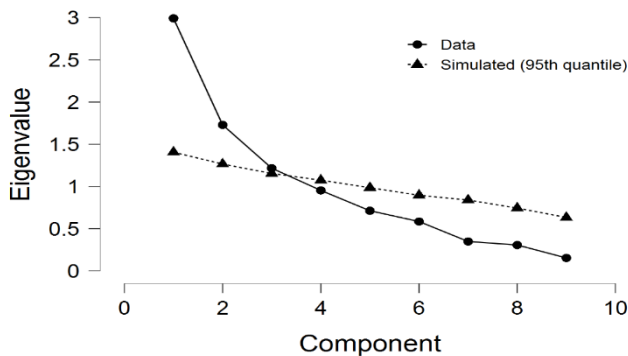

Figure 1. Regression of theoretical and empirical models
Source: Own elaboration

Figure 2 show structure of relationships between the nodes is grouped and focused on four three phases: formation, production and transfer Knowledge management is reproduced and transferred from the balance that its differences suppose in the COVID-19 era. The ability to adapt to risks and the dynamics of academic training are other features that distinguish the learning structure. That is, the model confirms the formative and reflective structure of three factors and corresponding indicators. Management is related to the production and transfer of knowledge. It is a three-dimensional reflective and formative factorial structure that explains the impact of the pandemic on professional practices and social service.

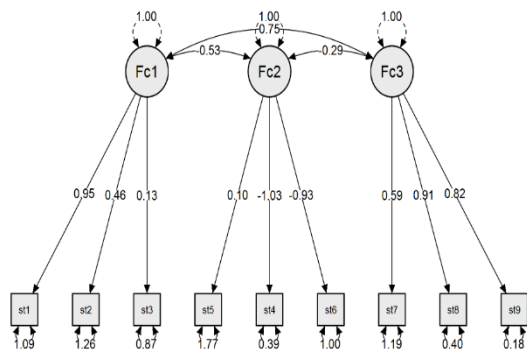

Figure 2. Confirmatory factorial model of knowledge management

Source: Own elaboration. Fc1 = Formation, Fc2 = Production, Fc3 = Transfer

Figure 3 show covariance matrix shows the prevalence of the factors and indicators of knowledge management. In this sense, it is possible to appreciate that a fourth factor related to the creation of knowledge that explains management in creative organizations would increase the relationships, the explained variance, and the confirmatory predictive power of the model. The

relationships between the indicators suggest a structure of three factors, although the relationship between knowledge management with production warns of an academic training linked to professional training, but the spurious relationship between production and transfer warns of a decoupling between professional training and labour.

	satlab1	satlab2	satlab3	satlab5	satlab4	satlab6	satlab7	satlab8	satlab9
satlab1	0								
satlab2	.05	0							
satlab3	.08	.22	0						
satlab5	.25	.04	.08	0					
satlab4	.02	.03	.22	.04	0				
satlab6	.09	.19	.07	0	0	0			
satlab7	.11	.11	.26	.07	.01	.27	0		
satlab8	.04	.2	.3	.39	.1	.08	.01	0	
satlab9	.02	.06	.15	.41	.1	.05	.03	0	0

Figure 3. Correlations between the indicators of the model

Source: Own elaboration

In summary, the results show three predominant factors: training, production, and transfer of knowledge. Each factor explains the factorial structure of knowledge management. From the confirmatory factorial model, it is possible not to reject the hypothesis regarding the significant differences between the structure reported in the literature with respect to the observations made in this study.

Discussion

Studies of organizational complexity and knowledge networks warn that learning processes suppose a latent instance that would correspond to a manifest instance. In this sense, the complexity would refer to the learning processes and implicit knowledge that only the labour systematization grants, but it would be a manifest complexity if such information processing, elaboration, and implementation of strategies are established in the tasks. The present work has found a prevalence of learning focused on the dissipation of information and knowledge rather than self-regulation, adaptation, or dynamism. This is so because educational quality policies seem to spread asymmetrically among teachers, students, and administrators, since the knowledge network they build seems to emerge from the diversity of contributions and the multiplicity of functions of its members rather than from a management system. production and transfer of leaders to talents.

Carreon et al., (2017) showed that although HEIs adjust their capacities to evaluation, accreditation, and

certification policies, they tend to innovate by assuming that the quality of processes and products are a requirement for the provision of funds. In this dynamic, HEIs are in a process that goes from institutionalism to governance or consensual management of the production and transfer of knowledge.

In the same sense, the present work has shown that dissipation as an indicator of the management, production and transfer of knowledge explains a dimension of its culture of success directed more as an innovation strategy than as a response to educational policy.

García, Bustos & Carreon (2017) warn that the opposite process to the establishment of a knowledge network would be in the management, production, and transfer of stigmas that, in the case of administrative stigmas, not only inhibit knowledge management but also reduce it to its minimum expression by cancelling the climate of collaboration and innovation necessary for the production and transfer of knowledge from teachers to students. In the present work, dissipation would not only explain the organizational culture of the knowledge network but would also explain how stigma underlies more authoritarian than democratic work cultures, distinguishable by their degrees of control over processes and production.

However, Carreon et al., (2017) showed that the organizational climate of a knowledge network, indicated by the climate of relationships, support, innovations and goals, reflects the incidence of educational quality policies on the collaborative dynamics of an HEI. In other words, state institutionalism, close to an authoritarian rather than democratic culture, encourages collaboration and guides it towards success in evaluation, accreditation, and certification, but limits its climate of innovation, thereby reducing the importance of dissipation in functions as in management strategies, production, and transfer of knowledge.

It is a crossroads, which on the one hand lies in the adjustment of the capacities to the state requirements to achieve accreditation and certification, but in another sense, it consists of the innovation of the processes as a competitive advantage of the HEI regarding to its competitors in raising funds.

In the HEI of this study, it has achieved the quality of its processes by adjusting its capabilities to state requirements, while generating a climate of innovation focused on the dissipation of its processes and products, strategies and functions.

Therefore, it is advisable to incorporate the organizational climate and its indicators of collaboration, innovation, tasks, goals, and relationships in the knowledge network model, focused on the complexity of organizational dissipative learning. This supposes the observation of two processes: one institutional focused on the climate of tasks and goals with respect to the educational quality policy and another inter-institutional focused on a climate of entrepreneurship and innovation related to the contingencies of the environment and the capacities of the organization.

Conclusion

The contribution of this work to the state of knowledge lies in the validity and structure of the confirmatory model relative to organizational complexity. The three factors found –formation, production, and transfer– correspond to a structure of possible relationships that explain organizational. In this way, the objectives, goals, and achievements are part of an informational and communicative process from which knowledge management is learned. Such a process is observable in creative process.

References

- Acar, Z., & Acar, P. (2014). Organizational culture types and their effects on organizational performance in Turkish hospitals. *Emerging Markets Journal*, 3(3), 1-15. <http://dx.doi.org/10.5195/emaj.2014.47>
- Aguilár, JA, Bautista, M., García, C., Hernández, G., Sandoval, FR, Pérez, G. and Valdés, O. (2016). Reliability and validity of an instrument that measures educational institutionalism in a public university in the State of Mexico. *Academic Research Without Borders*, 9(22), 1-16 <https://www.journalppw.com/index.php/jpsp/article/download/2983/1943>
- Anicijevic , N. (2013). The mutual impact of organizational culture and structure. *Economy Annals*, 58 (198), 35-60. https://www.researchgate.net/publication/288469770_The_mutual_impact_of_organizational_culture_and_structure
- Bautista, M., Delgado, ML, García, C., Valdés, O., Hernández, G., Castro, A. and Trujillo, KV (2016). Contrast of a model of organizational culture in community health centers before the informative dissemination of HIV / AIDS from Social Work. *Teaching and Research in Psychology*, 21(3), 248-255 https://www.researchgate.net/publication/309534079_Contrasting_a_model_of_organizational_culture_at_community_health_centers_facin_g_hiv_aids_informative_diffusion_from_a_social_work_perspective
- Carreón, J., Hernández, J., Castillo, MB and García, C. (2015). Contrast of an intentional network model. *Amapsi*, 1, 50-65 <https://www.nature.com/articles/s41467-021-22017-2>
- Carreón, J., Hernández, J., García, C. and Bustos, JM (2017). Perceptual factors of educational neoliberalism in a HEI in central Mexico. *Journal of Social Work*, 15, 50-57 http://www.scielo.org.mx/scielo.php?script=sci_arttext&pid=S1665-109X2015000200012

- Carreón, J., Hernández, J., Morales, ML and García, C. (2014). Discourses around a vocational training network. *Taltemoani*, 16, 104-133 https://www.researchgate.net/publication/275684670_The_Discourses_of_Vocational_Education_and_Training_A_Developmental_Response_from_a_European_Perspective
- Carreón, J., Hernández, J., Quintero, ML and García, C. (2016). Reliability and validity of an instrument that measures organizational intelligence in a university in Central Mexico. *Tlamati*, 7(2), 41-47 https://www.researchgate.net/publication/335526668_Reliability_and_validity_of_an_instrument_that_measures_knowledge_management
- Carreón, J., Hernández, J., Quintero, ML and García, C. (2017). Reliability and validity of an instrument that measures organizational collaboration in a public university in Huehuetoca (central Mexico). *Invurnus*, 12(2), 9-17 https://www.researchgate.net/publication/318014507_Confiabilidad_y_validez_de_un_instrumento_que_mide_la_colaboracion_organizacional_en_una_universidad_publica_de_Huehuetoca_centro_de_Mexico_Proyecto_financiado_por_la_UNAM-DGAPA-PAPIIT_IN305516_Autor_
- Cruz, O., Arroyo, P., and Marmolejo, J. (2016). Technological innovations in logistics: inventory management, information systems and outsourcing of operations. In M, Quintero., Sales, J., and Velázquez, E. (Coord.). *Innovation and technology challenges for its practical application in companies*. (pp.165-178). Mexico: Miguel Ángel Porrúa-Uaemex.
- Escobar, R. (2014). Neural networks, cognitive processes and behavior analysis. *International Journal of Behaviorism*, 2(1), 23-43 https://www.researchgate.net/publication/11418656_Behavior_analysis_and_neuroscience
- García, C. (2004). A modeling of the determinants of organizational effectiveness. *International Journal of Psychology*, 5(1), 1-12 <https://ibimapublishing.com/articles/JOMS/2014/273364/#:-:text=According%20to%20Kushner%20and%20Poole,goal%20attainment%2C%20and%20customer%20satisfaction.>
- García, C. (2005). An educational development program. *Education and Development*, 19, 1-12 <https://www.uepi.com/educational-development-program/>
- García, C. (2006). A university business model. *Social Sciences*, 3(2), 39-47 <https://www.salesforce.org/blog/universities-new-business-models/>
- García, C. (2007). An organizational development program. *Education and Digital Future*, 26, 1-11 <https://www.aihr.com/blog/organizational-development/>
- García, C. (2015). The knowledge network in a university with a system of professional practices and administrative technological social service. *Tlatemoani*, 18, 32-55 <https://ijassonline.in/AbstractView.aspx?PID=2021-9-1-1>
- García, C., Bustos, JM and Carreón, J. (2017). Exploratory dimensions of social and labor stigma. A Delphi study with undergraduate students. *Eureka*, 14(1), 55-68 <http://www.psicoeureka.com.py/sites/default/files/articulos/eureka-14-1-6.pdf>
- García, C., Carreón, J., Hernández, J., Bautista, M. and Méndez, A. (2012). Modeling of socio-psycho-organizational variables from a review of the state of the art. *Journal of Social Work*, 28, 13-69 <https://www.frontiersin.org/articles/10.3389/fpsyg.2019.02845/full>
- García, C., Carreón, J., Hernández, J., and Salinas, R. (2016). Governance of the actors and networks of technological innovation. In M, Quintero., Sales, J., and Velázquez, E. (Coord.). *Innovation and technology challenges for its practical application in companies*. (pp.79-94). México: Miguel Ángel Porrúa-Uaemex.
- García, C., Carreón, J., Sandoval, FJ, Bustos, JM, and Aguilar, JA (2016). Structure of the work culture in a public health promotion institution. *Arequipa*, 6 (1), 291-304 <https://www.ncbi.nlm.nih.gov/pmc/articles/PMC6106858/>
- García, C., Mejía, S., Hernández, J., López, S. and Salinas, R. (2015). Reliability and validity of an instrument that measures the organizational culture relative to educational institutionalism. *Hispano-American Notebooks of Psychology*, 15 (1), 42-52 https://www.researchgate.net/publication/340377839_IMPACT_OF_ORGANIZATIONAL_CULTURE_ON_INSTITUTIONAL_EFFECTIVENESS_IN_A_LOCAL_HIGHER_EDUCATION_INSTITUTION
- Hernandez, A., and Valencia, R. (2016). Innovation instruments: social networks in the internalization of micro, small and medium-sized Mexican companies. In M, Quintero., Sales, J. and Velázquez, E. (Coord.). *Innovation and technology challenges for its practical application in companies*. (pp.47-66). México: Miguel Ángel Porrúa-Uaemex.
- Mendoza, E., Ramírez, L., & Atriano, R. (2016). Use of media and technologies in the creation of an innovation system for the common good." In M, Quintero., Sales, J., and Velázquez, E. (Coord.). *Innovation and technology challenges for its practical application in companies*. (pp.95-114). México: Miguel Ángel Porrúa-Uaemex.
- Omotayo, O., & Adenike, A. (2013). Impact of organizational culture on human resource practices: a study of selected Nigerian private universities." *Journal of Competitiveness*, 5 (4), 115-133, <http://dx.doi.org/10.7441/joc.2013.04.07>
- Ortiz, P. & García, C. (2008). Study on climate and job satisfaction in a trading company. *Psychology for Latin America*, 13, 1-36 <https://ideas.repec.org/a/exp/bnsnes/v5y2017i2p83-90.html>
- Pérez, G., Valdés, O. & García, C. (2017). Determinants of academic habits on knowledge management. *Margin*, 85, 1-12 https://www.researchgate.net/publication/318940746_Factors_influencing_academics_knowledge_sharing_behaviour_in_United_Arab_Emirates_public_universities
- Pérez, MI, Carreón, J., Quintero, ML, Bucio, C., García, C. & Aguilar, JA (2016). The institutionalist agenda and knowledge management: Specification of an innovative entrepreneurship model. *Kayros*, 20 (38), 1-9 <https://dialnet.unirioja.es/servlet/articulo?codigo=7139804>
- Quintero, M., Velázquez, E., Sales, J., & Padilla, S. (2016). A review of the state of the art on SMEs. And innovation studies? In M, Quintero., Sales, J., and Velázquez, E. (Coord.). *Innovation and technology challenges for its practical application in companies*. (pp31-43). Mexico: Miguel Ángel Porrúa-Uaemex.
- Robles, C., Alvirer, L., Ortega, A., and Martínez, E. (2016). Culture of quality and innovation in microenterprises." In M, Quintero., Sales, J., and Velázquez, E. (Coord.). *Innovation and technology challenges for its practical application in companies*. (pp11-30). Mexico: Miguel Ángel Porrúa-Uaemex.
- Saansongu, E., and Ngutor, D. (2012). The influence of corporate culture of employee commitment to the organization. *International Journal of Business and Management*, 7(22), 1-8 <https://ccsnet.org/journal/index.php/ijbm/article/view/19358>
- Sales, J., Quintero, M., and Velázquez, E. (2016). Adaptation versus innovation: the formation of industrial districts from peasant communities. Santa Cruz Atizapan and Chiconcuac. In M, Quintero., Sales, J. and Velázquez, E. (Coord.). *Innovation and technology*

challenges for its practical application in companies. (pp.181-199). México: Miguel Ángel Porrúa-Uaemex.

Vázquez, C., Barrientos, B., Quintero, M., and Velázquez, E. (2016). Government support for innovation, technology and training of small and medium-sized companies in Mexico. In M, Quintero., Sales, J. and Velázquez, E., (Coord.). Innovation and technology challenges for its practical application in companies. (pp.67-78). Mexico: Miguel Ángel Porrúa-Uaemex.